



CONTINUOUS STEAM TUBE DRYER



ABOUT US

ANCO KNOWS RENDERING

Founded in 1902, ANCO has continued to innovate and hone our expertise in the manufacturing of quality rendering equipment for over a century.

Today, our product line and production capabilities have doubled in size, and we maintain an inventory of replacement parts to ensure you have little to no downtime.

This is what we do, but why we do it makes all the difference.

Our ultimate goal is to be your long-lasting, collaborative partner. We will work with you to find the best solution for your rendering needs, whether that's implementing a new system, or working with your existing equipment. Our equipment transforms organic waste into something purposeful, so we have a positive impact on our environment.

Our longevity makes us experts, but our customer care makes us the right partner. We look forward to working with you.



SYSTEMS SOLUTIONS SPARES

PRODUCT IN
100+
COUNTRIES

100+ YEARS

For over a century, ANCO has been providing quality, dependable products to fit any need within the rendering industry.

- BINS & TANKS
- SHREDDERS & GRINDERS
- COOKERS & HYDROLYZERS
- DRYERS
- SEPARATORS
- PRESSES
- VAPOR HANDLING
- ODOR CONTROL
- PUMPS & CONVEYORS
- PLC & HMI AUTOMATION

SPARE PARTS

ANCO is determined to provide critical spare parts to ensure your plant runs smoothly and without downtime.

OUR COMMITMENT

Providing exceptional customer service with fast turnaround, deep industry knowledge and long-term partnerships.

Offering full system control with automation using the latest PLC and HMI color touch screen functionality.

PROUDLY MADE IN THE USA



DRYING
Processes
feathers and
blood

- ASME code construction section VII Division 1
- 125 PSIG rating on Rotating Tube Bundle
- SS materials for wear and corrosion resistance
- Compact design takes up less space than older dryers
- Heavy-duty drive and bearings

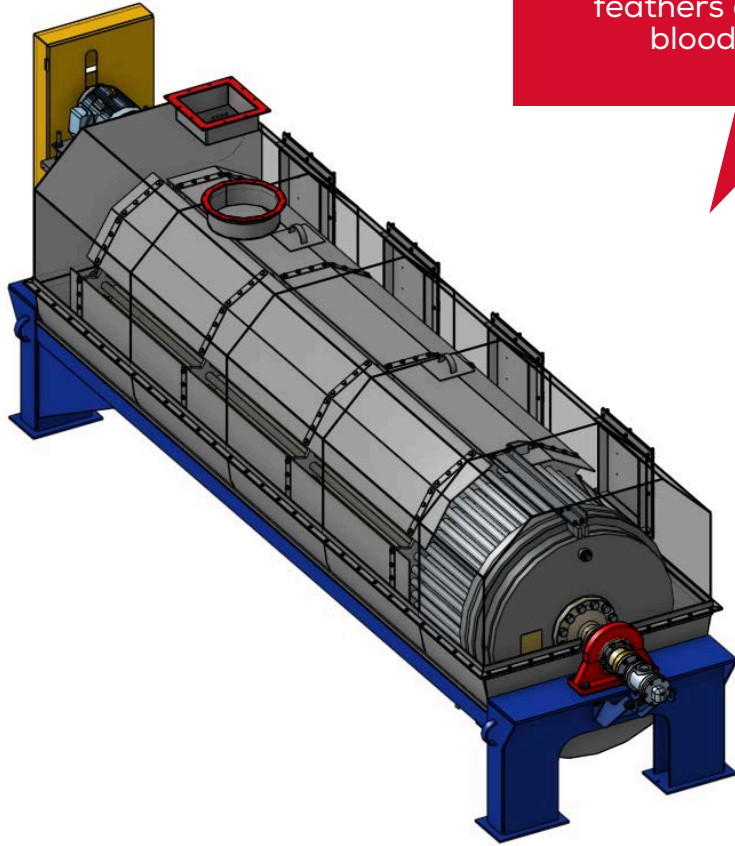

MODEL	HEATING SURFACE		DIMENSIONS						WEIGHT		POWER	
			LENGTH		WIDTH		HEIGHT					
	FT ²	M ²	FT	M	FT	M	FT	M	LBS	KG	HP	KW
1600-3	300	28	18	5.5	5	1.5	6.7	2.0	12,000	5,500	5	3.7
1600-4	400	37	18.5	5.6	5.4	1.6	7	2.1	13,500	6,200	7.5	5.5
1600-6	600	56	20.5	6.2	5.4	1.6	7	2.1	17,000	7,700	7.5	5.5
1600-8	800	74	24	7.3	5.4	1.6	7	2.1	23,500	10,700	10	7.5
1600-11	1,100	102	24.5	7.5	6	1.8	7.5	2.3	30,100	13,700	20	15

**PROVIDERS OF
SOLUTIONS,
SYSTEMS
& SPARES
FOR OVER 100 YEARS**



www.ancoeas.com | 336.855.7800
1420 Lorraine Ave. | High Point, NC 27263